

Failure Mechanism Analysis and Failure Number Prediction of Wind Turbine Blades

Yu Chun-yu, Guo Jian-ying, Xin Shi-guang

Higher Educational Key Laboratory for Measuring & Control Technology and Instrumentation of Heilongjiang Province
Harbin University of Science and Technology, China
e-mail: honeychunyu@126.com

Abstract

Pertinent to the problems that wind turbine blades operate in complicated conditions, frequent failures and low replacement rate as well as rational inventory need, this paper, we build a fault tree model based on in-depth analysis of the failure causes. As the mechanical vibration of the wind turbine takes place first on the blades, the paper gives a detailed analysis to the Failure mechanism of blade vibration. Therefore the paper puts forward a dynamic prediction model of wind turbine blade failure number based on the grey theory. The relative error between its prediction and the field investigation data is less than 5%, meeting the actual needs of engineering and verifying the effectiveness and applicability of the proposed algorithm. It is of important engineering significance for it to provide a theoretical foundation for the failure analysis, failure research and inventory level of wind turbine blades.

Keywords: wind turbine, blades, fault number, grey model, failure mechanism

1. Introduction

As the critical component, the blade plays an important role in wind turbines. As it sustains comprehensive effect of centrifugal force, fluid power, vibration, temperature difference (thermal stress) and media, it is fault-prone [1],[2]. With a great latitudinal expand, China has low temperature in the north, typhoons in the south, wind-borne sand in the northwest, all of which are the principal cause of frequent failures. According to JB/T 10194-2000, the limit design temperature of blades range from -30°C to $+50^{\circ}\text{C}$. However, in the northern area, the minimum temperature is below -30°C ; moreover, most of the wind turbines used in the wind farms in the early stage are of foreign technology which may not be entirely suitable to China's natural environment, especially the low-temperature environment. The indeterminate vibration generated in stall wind turbine blades by low temperature will damage the blade structure and thus affect the turbine's normal operation [3]. Most accidents due to blade faults are disastrous, for they will cause terrible loss, and have strong impact on turbine's economical and safe operation. Field data shows that mechanical vibration occurs first on blades [4]. Accordingly, analysis shall be given to the vibration Failure mechanism so as to put forward proposals for avoiding or minimizing vibration. When the blades failed, how to determine the blade's failure quantity in future by simple methods and higher accuracy, where reasonable inventory shall be kept, no excessive fund be taken up, requirements of recovery service be met, operation cost be minimized and non-planned shutdown time reduced. This is a challenging issue both at home and abroad in regard of reasonable reserve quantity of criminal components.

Now researches on blade Failure mechanism analysis, prediction of failure number and prediction of spare parts demand are less [5]. The prediction of failure number mostly employs traditional statistics and neural network theory [6],[7]. However, in the maintenance support field of wind turbine systems, catastrophic failure to critical components is usually a small sample and poor information. Thus, there are inherent defects in such methods.

Based on the detailed analysis of failure factors of wind turbine blades, the paper sets up a fault tree model of wind turbine blade. Making use of the fault tree, the paper makes a detailed logic analysis of the failure causes and probes the vibration Failure mechanism of blades. The failure number of wind turbine blades can be regarded as time series, so that the grey algorithm requires no mass data, neither predetermination of information characteristics. The paper advances a method of predicting the failure number of wind turbine blades based on dynamic grey model, predicting the failure number of wind turbine blades by use of small-

sample fault data and verifying the proposed algorithm in accordance with literature [8] measured data. The result has a 4.7% relative error with the measured data, meeting the actual needs of engineering, verifying the effectiveness of the proposed algorithm and solving the problem in prediction of failure number with partially known and partially unknown information.

2. Blade Fault Tree Model

A large-sized wind turbine system is mainly composed of wind wheel, gearbox, generator, yaw system, pitch system, braking system, lubrication system, electrical system and frequency converter in parallel [9],[10], as shown in Figure 1.

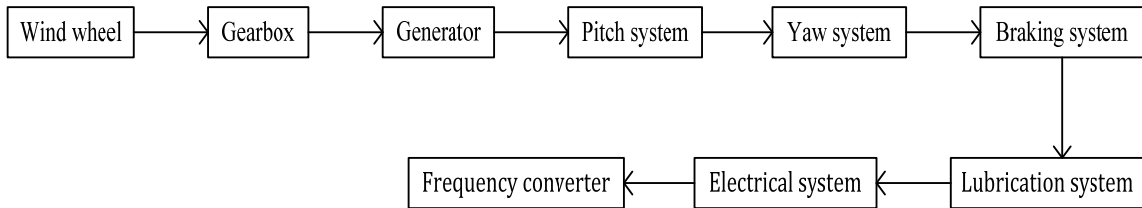

Figure 1. Reliability Logic Block Diagram of Wind Turbine

According to the statistical information of blade fault in wind farms, the fault tree shall be structured, as shown in Figure 2.

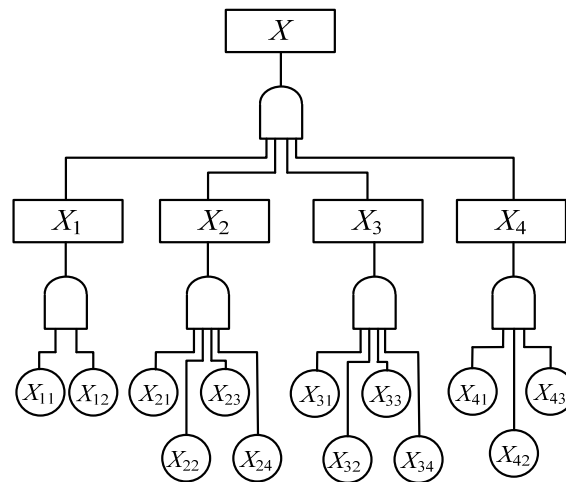

Figure 2. Blade Fault Tree

In the figure, X indicates the blade fault of top-tree event; X₁ is the blade mass unbalance of intermediate event, X₂ the aerodynamic unbalance, X₃ the blade crack damage, X₄ other faults; X₁₁ oil leak of pitch control valve; X₁₂ freezing corrosion dirt; X₂₁ wind vane inaccuracy; X₂₂ blade corrosion stain; X₂₃ control error; X₂₄ blade setting angle error; X₃₁ bad processing; X₃₂ material aging; X₃₃ lightning; X₃₄ improper transportation and installation; X₄₁ poor fit; X₄₂ unknown failure, and X₄₃ low performance.

The intermediate failure event X₁ comes from the logical combination of bottom events X₁₁ and X₁₂, that is:

$$X_1 = X_{11} + X_{12} \tag{1}$$

The intermediate failure event X_2 comes from the logical combination of bottom events X_{21} , X_{22} , X_{23} and X_{24} , that is:

$$X_2 = X_{21} + X_{22} + X_{23} + X_{24} \quad (2)$$

The intermediate failure event X_3 comes from the logical combination of bottom events X_{31} , X_{32} , X_{33} and X_{34} , that is:

$$X_3 = X_{31} + X_{32} + X_{33} + X_{34} \quad (3)$$

The intermediate failure event X_4 comes from the logical combination of bottom events X_{41} , X_{42} and X_{43} , that is:

$$X_4 = X_{41} + X_{42} + X_{43} \quad (4)$$

3. Blade Vibration Failure Mechanism Analysis

The stress on the wind turbine blades in rotation can be simplified as aerodynamic force, centrifugal force and gravity, expressed as formula (5), (6) and (7) respectively.

$$\begin{cases} F_{X-SA} = \frac{1}{2} \rho W^2 c (C_l \sin \alpha - C_d \cos \alpha) \\ F_{Y-SA} = \frac{1}{2} \rho W^2 c (C_l \cos \alpha + C_d \sin \alpha) \end{cases} \quad (5)$$

In the formula, ρ is the air density; W incoming wind velocity; c chord length; C_l lift coefficient; α angle of attack; C_d coefficient of drag; F_{X-SA} aerodynamic force in X direction; F_{Y-SA} the aerodynamic force in Y direction.

$$\begin{cases} F_{X-SG} = m_i(r) g \cos \Omega t \cos \delta \\ F_{Y-SG} = m_i(r) g \sin \Omega t \cos \delta \sin \beta \\ F_{Z-SG} = m_i(r) g \sin \Omega t \cos \delta \cos \beta \end{cases} \quad (6)$$

In the formula, $m_i(r)$ is the concentrated mass of blade elements at r ; Ωt the blade azimuth of rotation; δ the axial inclination; β the propeller pitch angle; F_{X-SG} gravity in X direction; F_{Y-SG} the gravity in Y direction; F_{Z-SG} the gravity in Z direction.

$$\begin{cases} F_{X-RP} = \int_r^R m_i(r) g \Omega^2 r dr \cos \Omega t \cos \delta \\ F_{Y-RP} = \int_r^R m_i(r) g \Omega^2 r dr \sin \Omega t \cos \delta \end{cases} \quad (7)$$

In the formula, F_{X-RP} is the centrifugal force in X direction; F_{Y-RP} the centrifugal force in Y direction.

Under the action of the three forces above, the blade will mainly develop flap, shimmy and torsion. These three mechanical vibrations join the aerodynamic force to produce aeroelastic problems. If their interaction is wakening, the vibration is steady, or more destructive flutter and radiation will occur. The blade's aeroelastic problems mainly involve "stall flutter" and "classic flutter".

In "stall flutter", blades will produce "limit cycle oscillation", which will, characteristic of steady vibration, and large and constant amplitude, ultimately result in "self-limited oscillation". If the blade has adequate torsional flexibility, it will produce "torsional divergence" or "non-

vibration failure”, namely buckling failure or torsional failure. Such flutter can be analyzed by nonlinear stability equations.

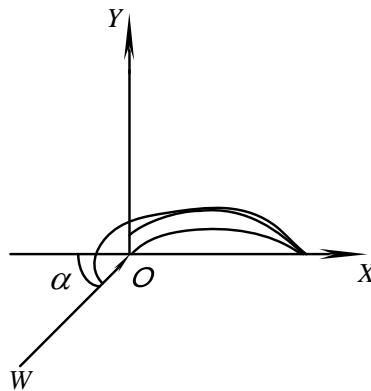

Figure 3. Blade Airflow Angle of Attack-Stalling Characteristics

The blade section is shown as Figure 3. When airflow comes from W direction, the angle of attack is α . When α is great, the airflow will separate in flowing across the blades, developing the “stall” called in aerodynamics.

The blade will produce a lift force F_l under the action of wind current, as shown in formula (8).

$$F_l = \frac{1}{2} \rho C_l S v^2 \quad (8)$$

In the formula, v is the inflow condition at a finite distance; and S is the blade area. The relation between C_l and the angle of attack α is as shown in Figure 4.

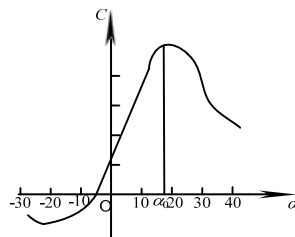

Figure 4. Lift Coefficient of Blade

In the figure, α_0 is the critical angle of attack. From the formula (8), the lift force of the blade is related to the angle of attack. When $\alpha < \alpha_0$, the lift increases with the increasing α ; when $\alpha > \alpha_0$, the lift decreases with the increasing α . In addition, when the tip of the blade makes bending motion upwards at a speed relative to the root, the variation of the angle of attack will change the lift. If $\alpha < \alpha_0$, the lift will decrease, hindering the blade tip bending upwards; if $\alpha > \alpha_0$, the lift increases, promoting the blade tip to bend upwards and aggravating the blade vibration so much that the blade will crack or rupture in a so short time (tens of or dozens of seconds).

“Classic flutter”, occurring in potential flow, is a self-sustained unsteady oscillation. It can result in sudden oscillation of blades, which will increase to the extent of damage.

If the blade deviates upwards from the equilibrium position, the elastic restoring force will drag it to the equilibrium position and thus an inertia force acts on the blade’s center of gravity. The torque of the inertia force to the torsion center will reduce the angle of attack of the blade, and thus producing an additional aerodynamic force to speed up the blade’s move to the equilibrium position. During the course, the aerodynamic force is an exciting force, which is directly proportional to the blade’s rotation rate, and inversely proportional to the blade’s damping force.

Therefore, the most effective way to prevent blade fluttering is to move the blade’s center forwards to reduce the inertia moment. With field investigation, other failures can be eliminated by such measures as regular inspection, regular maintenance, regular cleaning, optimization of control policy and arithmetic method and adjustment of setting angle. The knife scars or damage on the component surface can be treated by finish machining, with consideration of material strength and techniques.

4. Grey Algorithm

The grey algorithm regards random quantities as grey quantities, so that it needs not study the probability distribution regularities in data processing, but lays particular emphasis on the search of laws between data. Through data processing, new data will be produced, and implicit laws of initial data will be figured out accordingly [11],[12].

4.1 GM (1,1) Model

Given that $X^{(0)}$ is the original series,

$$X^{(0)} = [x^{(0)}(1), x^{(0)}(2), \dots, x^{(0)}(n)] \quad (9)$$

For the convenience of model building, a new series $Y^{(0)}$ will be generated from every series by formula (10).

$$y^{(0)}(i) = \frac{x^{(0)}(i)}{x^{(0)}(1)} \quad (10)$$

In the formula, $i = 1, 2, \dots, n$.

$$Y^{(0)} = [y^{(0)}(1), y^{(0)}(2), \dots, y^{(0)}(n)] \quad (11)$$

A first accumulation given to $Y^{(0)}$, the series $Y^{(1)}$ of failure will be generated from formula (12).

$$y^{(1)}(k) = \sum_{i=0}^k y^{(0)}(i), \quad k = 1, 2, \dots, n \quad (12)$$

$$Y^{(1)} = [y^{(1)}(1), y^{(1)}(2), \dots, y^{(1)}(n)] \quad (13)$$

The background value will be structured from $Y^{(1)}$, that is:

$$Z^{(1)} = [z^{(1)}(2), z^{(1)}(3), \dots, z^{(1)}(n)] \quad (14)$$

In the formula, $z^{(1)}(k)$ can be obtained from formula (11).

$$z^{(1)}(k) = ay^{(1)}(k-1) + (1-a)y^{(1)}(k), \quad k = 2, 3, \dots, n \quad (15)$$

The corresponding whitenization equation is as follows:

$$\frac{dY^{(1)}}{dt} + aY^{(1)} = b \quad (16)$$

In the formula, a is the developing coefficient, whose effective interval is $(-2, 1)$; b is the grey variable, which can be obtained from formula (17).

$$\hat{a} = (a, b)^T = (B^T B)^{-1} \cdot B^T \cdot Y_n^* \quad (17)$$

In the formula, Y_n^* and B are obtained from formulas (18) and (19) respectively.

$$Y_n^* = [y^{(0)}(2), y^{(0)}(3), \dots, y^{(0)}(n)]^T \quad (18)$$

$$B = \begin{bmatrix} -\frac{y^{(1)}(1) + y^{(1)}(2)}{2} & 1 \\ -\frac{y^{(1)}(2) + y^{(1)}(3)}{2} & 1 \\ \vdots & \vdots \\ -\frac{y^{(1)}(n-1) + y^{(1)}(n)}{2} & 1 \end{bmatrix} \quad (19)$$

The solution of the differential equation (16) is:

$$\hat{y}^{(1)}(k+1) = (y^{(0)}(1) - \frac{b}{a}) \cdot e^{-ak} + \frac{b}{a} \quad (20)$$

In the formula, $k = 1, 2, \dots, n$.

$\hat{y}^{(1)}(k+1)$, with inverse accumulation, can be reduced to be as follows:

$$\hat{y}^{(0)}(k+1) = \hat{y}^{(1)}(k+1) - y^{(1)}(k) \quad (21)$$

4.2 Dynamic Grey Prediction Model

To predict the failure number needs to build a prediction model according to the continuously obtained failure number, that is, the latest data serves as reference point. Thus, the new model in the topology models is used to approximate to the actual vale.

If as many as k data are used to build a basic prediction model, the $k+1$ data and above will be predicted. When the $k+1$ data is predicted, it shall be compared with the actual value to decide whether it is true or false. If it's true, it shall be added into the original series to form a new series composed of $k+1$ data; and then the $k+1$ data is used to build a prediction model, producing a new dynamic model.

5. Engineering Application Example

The paper takes the fault data in Table 4-13 in the literature [8] as original data, which is now tabulated in Table 1, to predict the failure number of blades in the next year. (calculated by 30 days a month)

Tabel 1. Cumulative failure time of blades (days)

i	1	2	3	4	5	6	7	8
t_i	753	800	902	924	1047	1109	1151	1153

The prediction results are tabulated in Table 2.

Tabel 2. Forecasting results

Future interval (day)	90	180	360
Literature (piece)	3.02	6.46	14.33
The paper (piece)	2.5019	6.4333	12.5695
Actual (piece)	2	6	12

The variance of the actual data is 0.5, indicating a high dispersion degree; the residual variance is 0.23232572, indicating a low dispersion degree. Their specific value is $C=0.464651$, indicating that the difference between the calculated value from the model and the actual value is not so discrete though the original data is very discrete.

6. Conclusions

With the wind turbine blades as the object and the blade's failure number as the contents, the paper builds a fault tree model for wind turbine blades, analyzes the vibration failure mechanism and constructs a dynamic grey prediction model of wind turbine blade failure number based on small sample data. The relative error of the prediction results by the dynamic grey prediction model of wind turbine blade failure number shows that the mode is of extensive engineering application value, providing a theoretical foundation for the reserve of critical components.

Acknowledgements

This work was supported by the Research Foundation of Education Bureau of Heilongjiang Province, China (Grant No. 12511093).

References

- [1] Xie Zhijiang, Liu Jun, Tang Yike et al. Diagnostic method of blade-to-blade dynamic space for turbo machinery's blade faults. *Chinese Journal of Mechanical Engineering*. 2004; 40(8): 96-99.
- [2] Xie Zhijiang, Tang Yike, Han Zhihua. Diagnosis Method of Dynamic Parameter in Blade-to-blade for Turbo Machinery's Blade Fault. *China Mechanical Engineering*. 2003; 14(13): 1081-1083.
- [3] http://www.newenergy.org.cn/Html/0065/2006522_10094.html
- [4] QIAO Yin-hu, ZHANG Chun-yan. Vibration Fatigue Mechanism of Wind Turbines' Blade. *Mechanical engineer*. 2007; (4): 55-57.
- [5] WANG Yi-ping, SUN Wen-lei, ZHAO Qun. Research on Dynamic Characteristics of Large Wind Turbine Flexible Blades. *Machine Building & Automation*. 2011; 40(5): 134-136.
- [6] ZHU Huayuan, ZHAO Jingcheng, XU Weiqin. Failure number prediction of aircraft master oily pump based on SVM regression algorithms. *Aviation maintenance & engineering*. 2007; (4): 25-26.
- [7] MA Wei-jun. Forecasting of product trouble based on an improved grey GM(1, 1) model. *Journal of Natural Science of Hei Long Jiang University*. 2005; 22(3): 389-392.
- [8] Sun Yongquan. *Research on system reliability growth prediction theory and method*. Harbin university of science and technology. 2011; 6.
- [9] ZHOU Zhen, MA Dezhong, YU Xiaoyang, et al. Application of fuzzy grey relational analysis in fault tree analysis. *Electric machines and control*. 2012; 16(3): 60-64.

-
- [10] Yang Mingming. *Fault mode statistic & analysis and failure diagnosis of large-scale wind turbine*. 2009; 1.
- [11] LI Junfang, ZHANG Buhan, XIE Guanglong, et al. Grey predictor models for wind speed-wind power prediction. *Power System Protection and Control*. 2010; 38(19): 151-158.
- [12] ZHU Xian-hui¹, CUI Shu-mei¹, SHI Nan, et al. Grey prediction model of motor reliability of electric vehicle. *Electric Machines and Control*. 2012; 16(8): 42-45.